



VTA12-100 (12V 111AH/20HR) SEALED LEAD ACID Battery

The Valiant VTA series AGM batteries are designed for float and cycling applications. The VTA series offers a 30% higher cycle life than standard AGM and a 10-year float life that is achieved through a slightly different active paste material and a slightly stronger electrolyte. They are perfectly suited for UPS/Telecom, remote site, and emergency power systems.

**12V
100Ah**

**AGM
Technology**

**VRLA
Battery**



Applications

- Telecom, controls, remote site
- UPS and inverter systems
- Solar and wind systems
- Emergency backup power systems
- RV and marine

General Features

- 30% more cycle life
- Deep discharge recovery, 700 cycles @ 50% DOD
- Thick plate design with high tin/low calcium alloy
- 10 years service life in floating applications
- High power density

Dimensions & Weight

Length(mm/inch)	307/12.0
Width(mm/inch)	169/6.65
Height(mm/inch)	211/8.3
Total Height(mm/inch)	215/8.4
Weight(kg/lbs)(±3%)	26.5/58.4

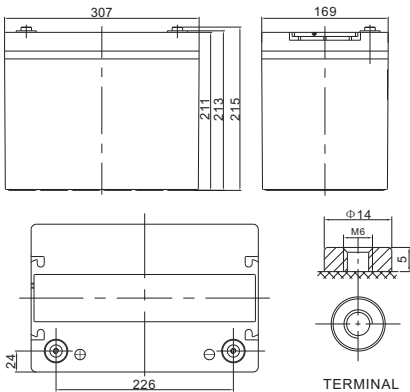

Battery Discharge Table

Technical Specifications

Nominal Voltage		12V (6 cells per unit)
Design Floating Life @ 25°C		10 Years
Nominal Capacity @ 25°C	20 hour rate@5.55A,10.8V	111Ah
	10 hour rate (10.0A, 10.8V)	100Ah
	5 hour rate (18.3A, 10.5V)	91.5Ah
	1 hour rate (66.5A,9.6V)	66.5Ah
Capacity @ 25°C		
Internal Resistance	Full Charged Battery@ 25°C	≤5.3mΩ
Ambient Temperature	Discharge	-15°C~45°C
	Charge	-15°C~45°C
	Storage	-15°C~45°C
Max. Discharge Current		@ 25°C 600A(5s)
Capacity affected by Temperature (10 hour)	40°C	105%
	25°C	100%
	0°C	85%
	-15°C	65%
Self-Discharge@25°C per Month		3%
Charge (Constant Voltage) @ 25°C	Standby Use	Initial Charging Current Less than 25.0A Voltage 13.6-13.8V
	Cycle Use	Initial Charging Current Less than 25.0A Voltage 14.4-14.9V



COMPLIED STANDARDS
 IEC 60896-21/22 JIS C8704
 YD/T799 BS6290 part4
 GB/T 19638 CE

Discharge Constant Current per Cell (Amperes at 25°C)

F.V/Time	15min	30min	45min	1h	2h	3h	5h	8h	10h	20h
1.60V	168.8	105.1	75.4	66.5	40.5	29.6	19.1	11.6	10.40	5.77
1.65V	161.8	102.2	73.4	64.7	39.8	29.1	18.8	11.5	10.30	5.72
1.70V	154.8	99.4	71.3	63.0	39.1	28.6	18.5	11.4	10.20	5.66
1.75V	147.7	96.6	69.3	61.2	38.1	27.9	18.3	11.3	10.10	5.61
1.80V	140.7	93.8	67.3	59.4	37.2	27.2	18.0	11.2	10.00	5.55

Discharge Constant Power per Cell (Watts at 25°C)

F.V/Time	15min	30min	45min	1h	2h	3h	5h	8h	10h	20h
1.60V	314.9	195.9	140.6	124.1	75.6	55.3	35.6	21.7	19.4	10.8
1.65V	301.8	190.7	136.8	120.8	74.2	54.3	35.1	21.5	19.2	10.7
1.70V	288.6	185.4	133.0	117.4	72.8	53.3	34.6	21.3	19.0	10.6
1.75V	275.5	180.2	129.3	114.1	71.1	52.0	34.1	21.1	18.8	10.5
1.80V	262.4	174.9	125.5	110.8	69.4	50.7	33.6	20.9	18.7	10.4



Performance Characteristics

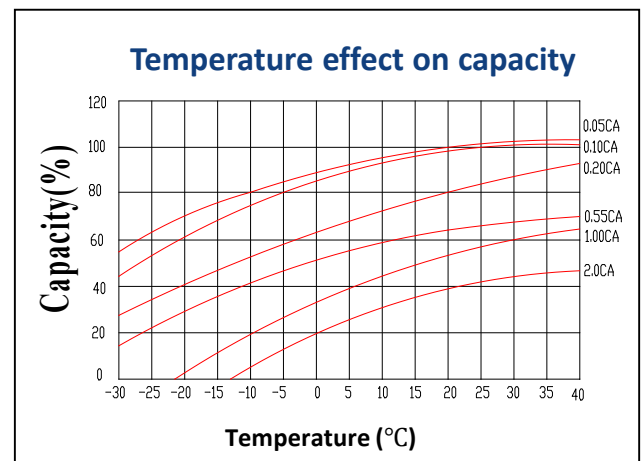
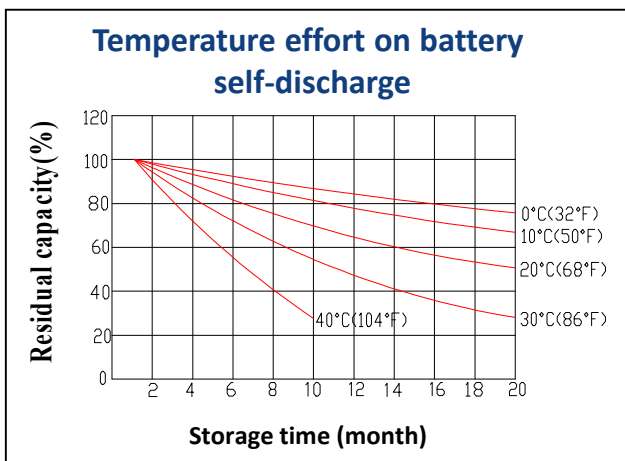
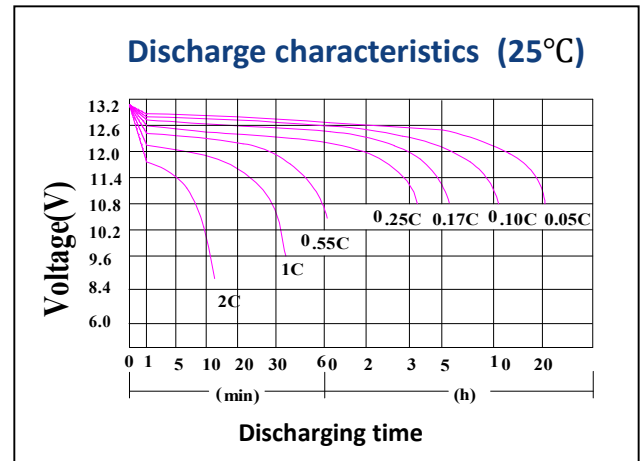
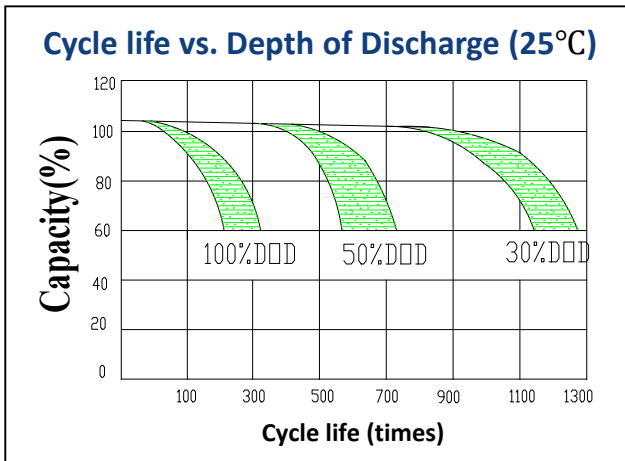
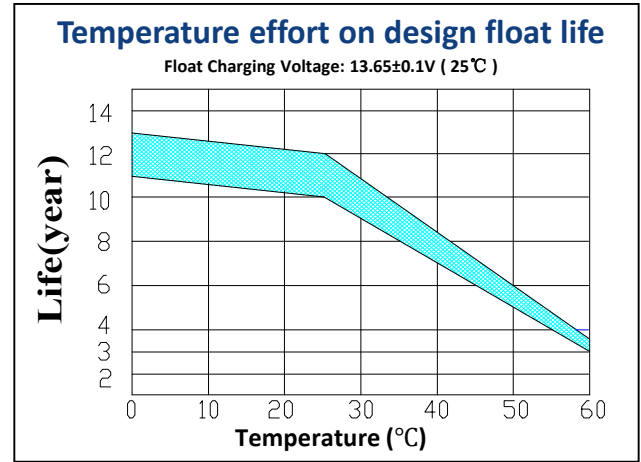
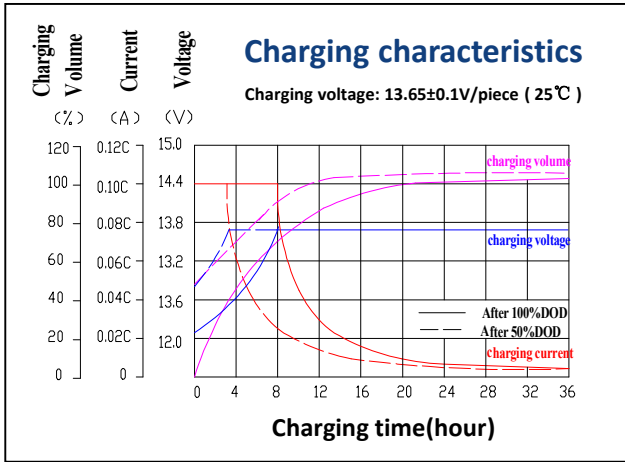

Battery Construction

Component	Positive Plate	Negative Plate	Container & Cover	Safety Valve	Terminal	Separator	Electrolyte	Pillar Seal
Features	Thick high Sn low Ca grid with special paste	Balanced Pb-Ca grid for improved recombination efficiency	ABS (UL94-VO optional)	Flame Si-Rubber and aging resistant	M6	Advanced AGM separator for high pressure cell design	Dilute high purity sulfunc acid	Two layers epoxy resin seal