

VALIANT VHD (High Rate) series Valve Regulated Lead Acid (VRLA) battery is designed for heavy load discharge applications with over 8 years design life in float service. By using strong grids, thick plate and specially designed active material. It is with lower I.R, lower self discharge rate, high power, and longer service life. The VHD series battery offers 30% more power output than the standard series. It is suitable for high power standby used, such as datacenter, UPS, EPS etc.

**12V
300W**

**AGM
Technology**

**High Rate
Discharge**



COMPLIED STANDARDS

**IEC 60896-21/22
YD/T799
GB/T 19638**

**JIS C8704
BS6290 part4
CE**

Applications

- UPS & EPS
- Emergency lighting Systems
- Medical Equipment
- The office computer
- Alarm Systems

Dimensions & Weight

Length(mm/inch)	260/10.24
Width(mm/inch)	169/6.65
Height(mm/inch)	211/8.31
Total Height(mm/inch)	215/8.46
Weight(kg/lbs)(±3%)	25/55.11

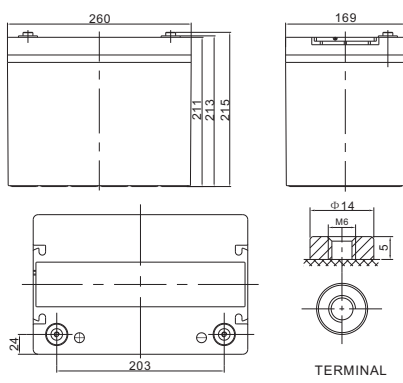

Battery Discharge Table

General Features

- Thicker plate with high Tin low Calcium alloy
- High Reliability and Good Quality
- Deep Discharge Recovery
- High Power Density
- Longer Service Life, in both Float or Cyclic

Technical Specifications

Nominal Voltage		12V (6 cells per unit)
Design Floating Life @ 25°C		10 Years
Watts/cell@ 25°C	@15min, 1.67V	300W
Capacity @ 25°C	10 hour rate (8.0A, 10.8V)	80.0Ah
	5 hour rate (14.0A, 10.5V)	70.0Ah
	1 hour rate (53.7A, 9.6V)	53.7Ah
Internal Resistance	Full Charged Battery@ 25°C	≤5.5mΩ
Ambient Temperature	Discharge	-15°C ~ 45°C
	Charge	-15°C ~ 45°C
	Storage	-15°C ~ 45°C
Max.Discharge Current @ 25°C		480A (5s)
Capacity affected by Temperature (10 hour)	40°C	102%
	25°C	100%
	0°C	85%
	-15°C	65%
Self-Discharge@25°C per Month		3%
Charge (Constant Voltage) @ 25°C	Standby Use	Initial Charging Current Less than 16.0A Voltage 13.6-13.8V
	Cycle Use	Initial Charging Current Less than 16.0A Voltage 14.4-14.9V

Discharge Constant Current per Cell (Amperes at 25°C)

F.V/Time	5min	10min	15min	20min	25min	30min	45min	60min	90min	2h	3h	10h
1.60V	244.6	193.6	163.7	148.6	126.7	106.5	77.4	53.7	44.9	34.0	24.6	8.80
1.67V	240.1	190.1	160.7	146.8	124.4	104.5	76.0	52.7	44.1	33.4	24.2	8.60
1.70V	235.7	186.5	157.8	144.1	122.1	102.6	74.6	51.7	43.2	32.7	23.7	8.50
1.75V	231.2	183.0	154.8	139.5	119.8	100.7	73.2	50.8	42.4	32.1	23.3	8.30
1.80V	222.4	176.0	148.8	133.6	115.2	96.8	70.4	48.8	40.8	30.9	22.4	8.00

Discharge Constant Power per Cell (Watts at 25°C)

F.V/Time	5min	10min	15min	20min	25min	30min	45min	60min	90min	2h	3h	10h
1.60V	456.2	361.0	305.2	277.2	236.4	198.6	144.4	100.2	83.7	63.4	45.9	16.4
1.67V	447.8	354.5	299.7	273.7	231.9	194.9	141.7	98.3	82.2	62.3	45.1	16.0
1.70V	439.6	347.9	294.3	268.7	227.7	191.3	139.1	96.4	80.5	61.0	44.2	15.9
1.75V	431.2	341.4	288.7	260.2	223.5	187.8	136.5	94.7	79.0	59.9	43.5	15.5
1.80V	414.8	328.2	277.5	249.2	214.8	180.5	131.3	91.0	76.1	57.6	41.8	14.9

Performance Characteristics

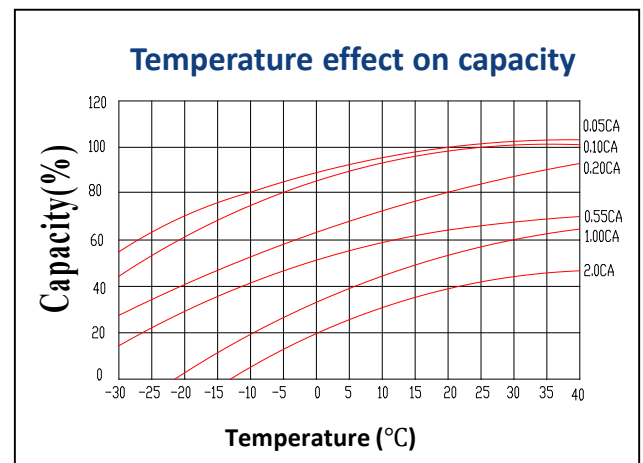
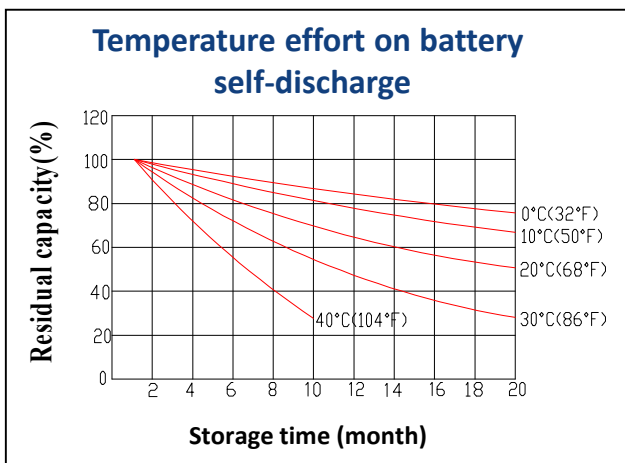
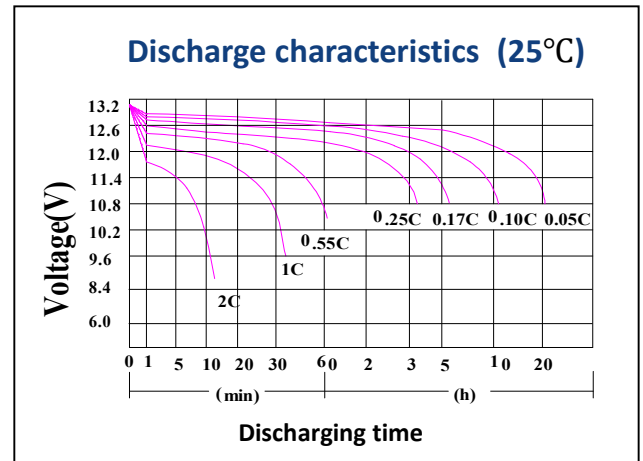
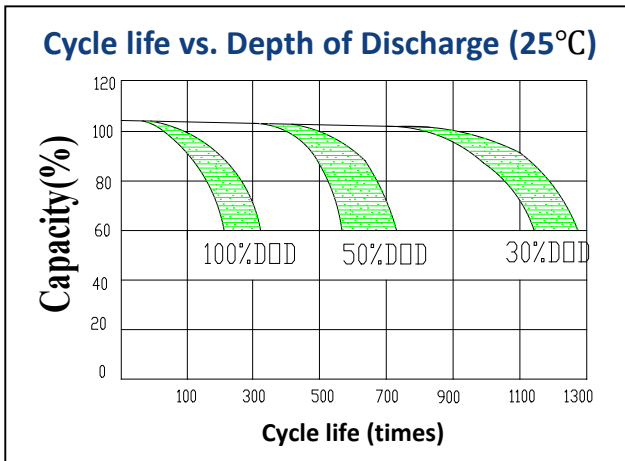
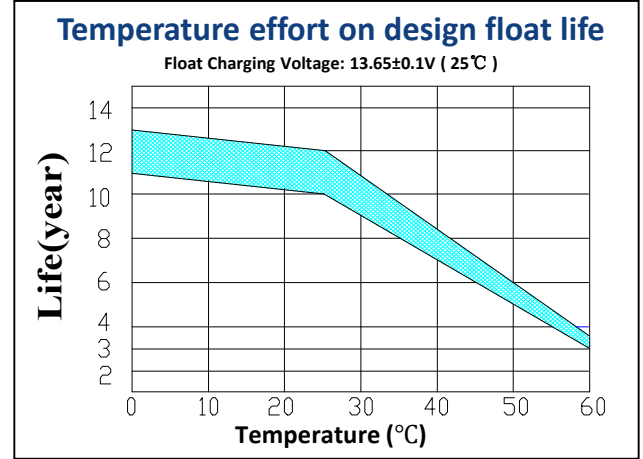
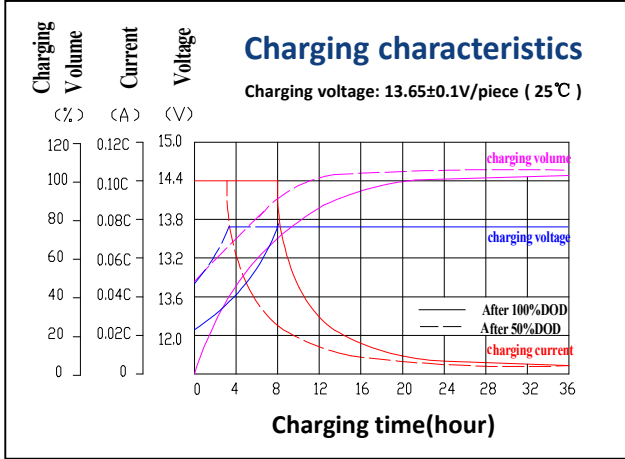

Battery Construction

Component	Positive Plate	Negative Plate	Container & Cover	Safety Valve	Terminal	Separator	Electrolyte	Pillar Seal
Features	Thick high Sn low Ca grid with special paste	Balanced Pb-Ca grid for improved recombination efficiency	Fire resistant ABS (UL94-V0 optional)	Flame Si-Rubber and aging resistant	Female Copper Insert M6	Advanced AGM separator for high pressure cell design	Dilute high purity sulfuric acid	Two layers epoxy resin seal